

IE

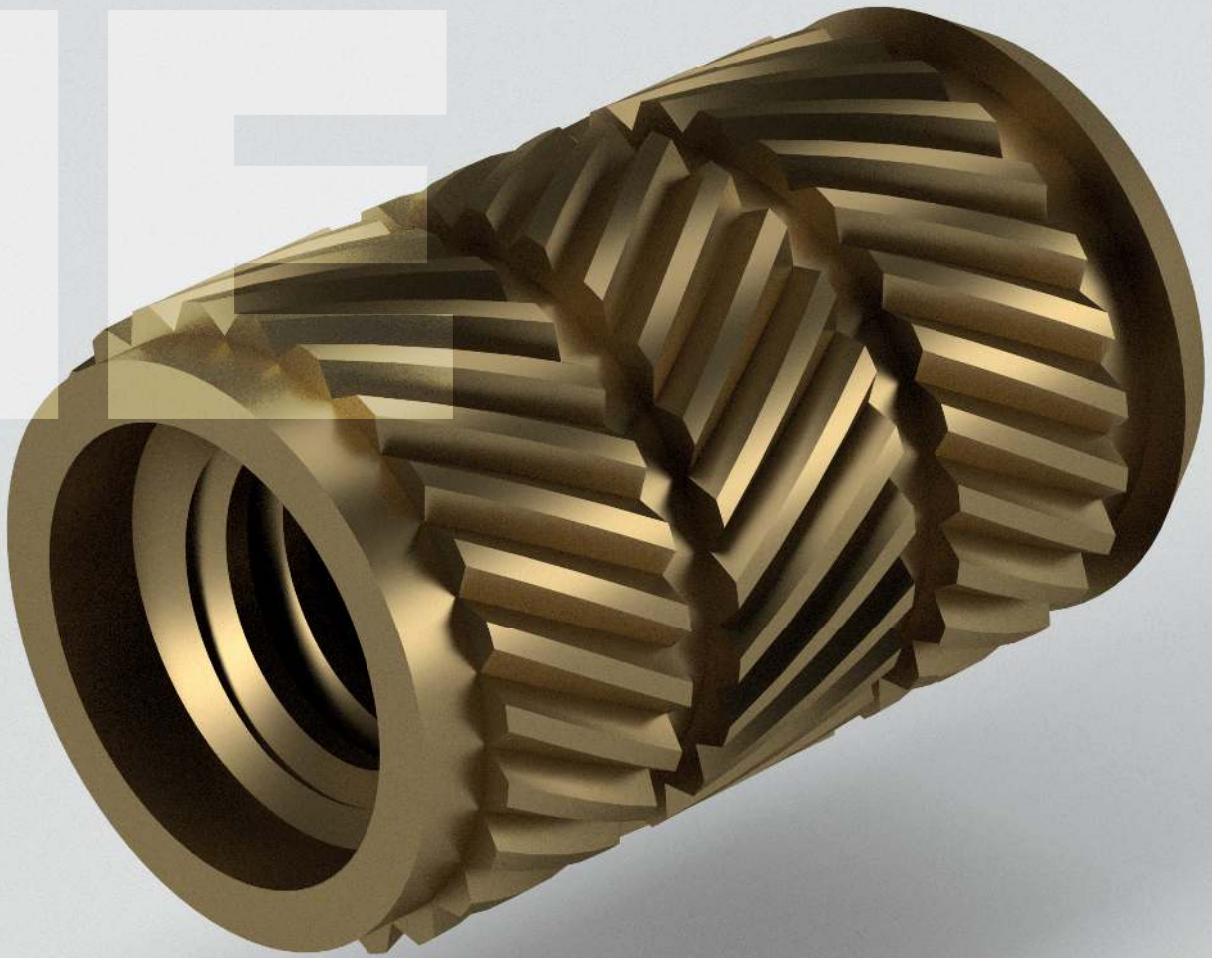

The IE range of blind inserts are designed for overmoulding into thermoplastic and thermoset materials.

Opposing knurling and undercuts give excellent rotational and pull out performance.

Counter-bore prevents ingress of plastic when located onto a shouldered pin.

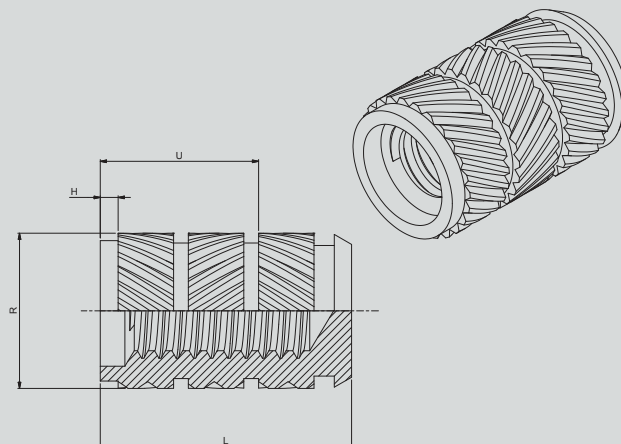

THREAD SIZES	L	R	U	H
ISO Metric	mm	mm	mm	mm
M2	5.5	3.4	3.6	1.0
M2.5	6.4	4.3	4.0	1.2
M3	7.3	4.7	4.6	1.3
M3.5	9.2	5.5	6.0	1.6
M4	10.2	6.3	6.7	1.8
M5	11.2	7.3	7.4	2.0
M6	14.4	9.8	8.1	2.0
M8	16.5	11.4	11.1	2.3
M10	17.9	13.8	11.9	2.4

Brass - to BS EN 12164 CW614N - RoHS COMPLIANT