

Square Taper Steel Washers (for use with I sections)

DIN 435

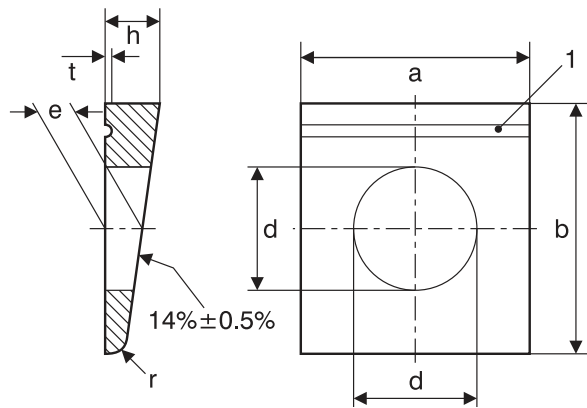

1 Rolled-in grooves for indication of $(14 \pm 0.5) \%$ taper (on top side)

DIN 435 Dimensions of washers

Nominal size	For thread size	Hole diameter d		Width a			Length b			auxiliary dimension e ^{1),2)}	Thickness h			Radius r	Groove depth t	Approx. mass (7.85 kd/dm ³) per 1000 units, in kg
		nom.	max.	nom.	min.	max.	nom.	min.	max.		nom.	min.	max.			
9.0	M8	9	9.36	22	20	24	22	21.35	22.65	3.05	4.6	3.6	5.6	1.2	0.5	10.2
11.0	M10	11	11.43	22	20	24	22	21.35	22.65	3.05	4.6	3.6	5.6	1.2	0.5	9.4
13.5	M12	13.5	13.93	26	24	28	30	29.35	30.65	4.10	6.2	5.0	7.4	1.6	0.7	20.1
17.5	M16	17.5	17.93	32	29.5	34.5	36	35.20	36.80	5.00	7.5	6.3	8.7	2.0	0.8	35.6
22.0	M20	22	22.52	40	37.5	42.5	44	43.20	44.80	6.10	9.2	8.0	10.4	2.4	0.9	67.0
24.0	M22	24	24.52	44	41.5	46.5	50	49.20	50.80	6.50	10.0	8.8	11.2	2.4	1.0	90.0
26.0	M24	26	26.52	56	53	59	56	55.05	56.95	6.90	10.8	9.3	12.3	2.4	1.0	143.0
30.0	M27	30	30.52	56	53	59	56	55.05	56.95	6.90	10.8	9.3	12.3	2.4	1.0	133.0